



Your Global Marking Partner since 1940



DOT PEEN SOLUTIONS CATALOGUE

Machines and systems
for industrial marking

www.automator.com



WHY CHOOSE AUTOMATOR?



Since its founding in 1940, AUTOMATOR has been focused exclusively on Industrial Marking Products and Solutions making us the largest manufacturer of marking equipment in the world.

No matter how you want to permanently identify your product, AUTOMATOR has a solution that will exceed your expectation making a mark that will enhance your part and limit your liabilities.

Our GLOBAL network of partners (not just distributors!) are available in 102 countries serving 100+ business sectors. No matter where you are in this world, we are there to support you and our marking products, birth to death.

**We are your global
marking partner
since 1940!**



Laser



Dot peen



Roll stamping



Impact



Presses



Scribe

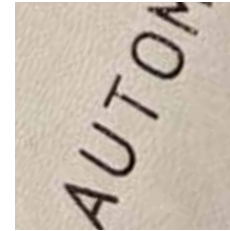

Hot foil



Chem-etch

DOT PEEN TECHNOLOGIES



Vibrating Dot Peen

Characters are marked with a small pin while vibrating. Highly recommended for fast marking with very high quality needs.



Electric Dot Peen

The pin is moved electrically by drive and return electric spring solenoid. Air not required. Recommended for high quality needs.



Pneumatic Dot Peen

The Pin is moved automatically by opening and closing the drive and return air. Recommended for marking on irregular and rough surfaces.



Deep Dot Peen

The Air Solenoid has an increased capacity. Specialized pins are required for deep markings on the most resistant materials.



Controlled Dot Peen

Font characters are created with possibility to specify the density of the dots to be marked from 0 to 80 pixel/cm. Recommended for deep marking.



Scribe Marking

Markings are made by striking the surface and removing the material for deep and silent marking.

Automator is certified CISQ,
the consortium for IT Software Quality



Automator Group believes in rational energy use as input
in the design and development of its marking systems



Automator is certified ISO 9001 IQ Net since 2003



Automator Group believes that all its machinery must be
designed and produced according to the concept
of "green philosophy"



AC500

CONTROLLER FOR DOT PEEN AND SCRIBE MACHINES



UNIVERSAL AND FULL OPTIONALS

The AC500 controller can be used with a PC or alone with the special Automator MarkAlone™ technology. The 7" touchscreen makes the many software's features easy to manage and use. For the first time, industrial marking reaches the maximum in efficiency and intuitive simplicity.



Watch video now!



OPTIONAL EXTERNAL COMMUNICATIONS PROTOCOLS

(*) All the logos are property of their own companies

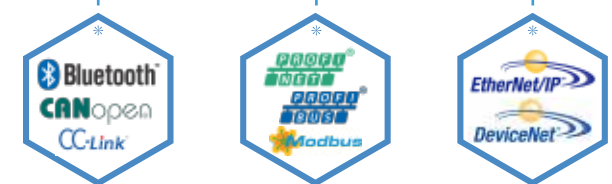

Head/controller cable

I/O Port

Ethernet/PC

ON/OFF button

External Power Supply 48V

Fuse

External communications on the side

I/O RS 232

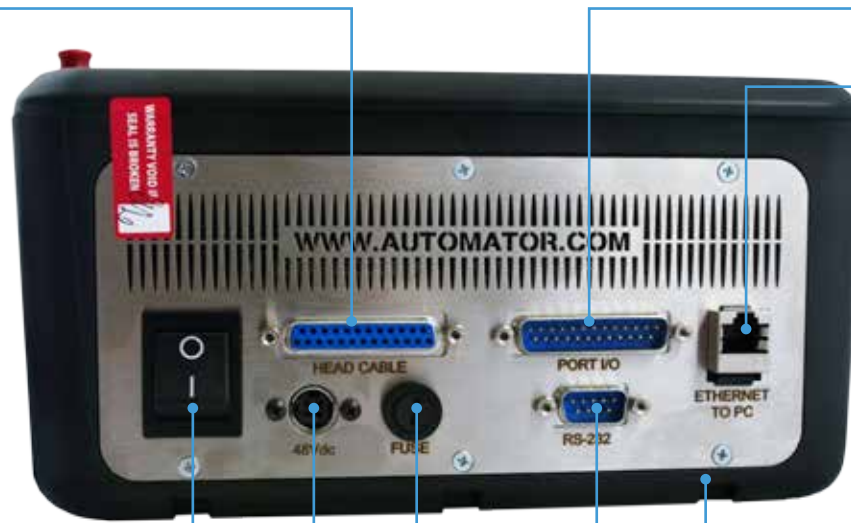

NEW CONNECTIONS PLATE

Standard Certifications for USA: (International Technology Equipment Safety part 1: general requirements, 609501) and Canada (International Technology Equipment Safety part 1: general requirements Amendment 1:2011, Amd. 2: 2014, CSA C22.2#60950-1)

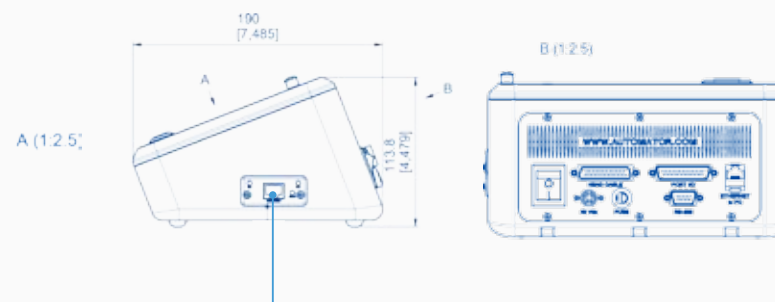
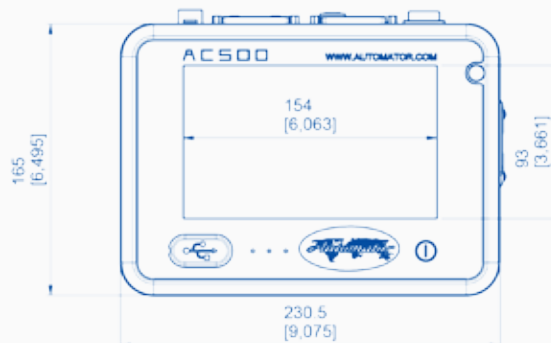

OPTIONAL EXTERNAL COMMUNICATIONS PROTOCOLS



The AC500 controller can be used with a PC or alone with the special Automator MarkAlone™ Up to 8 programs management.

AC250

CONTROLLER FOR DOT PEEN

For all models



UNIVERSAL AND
COST-EFFECTIVE

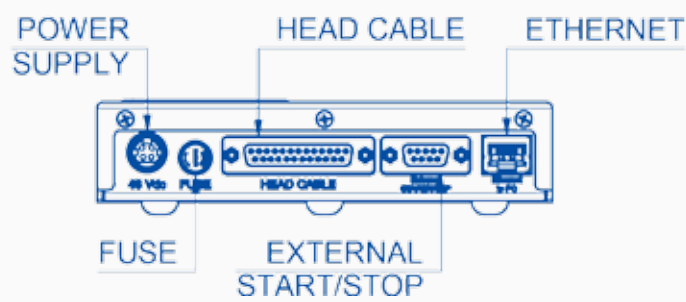
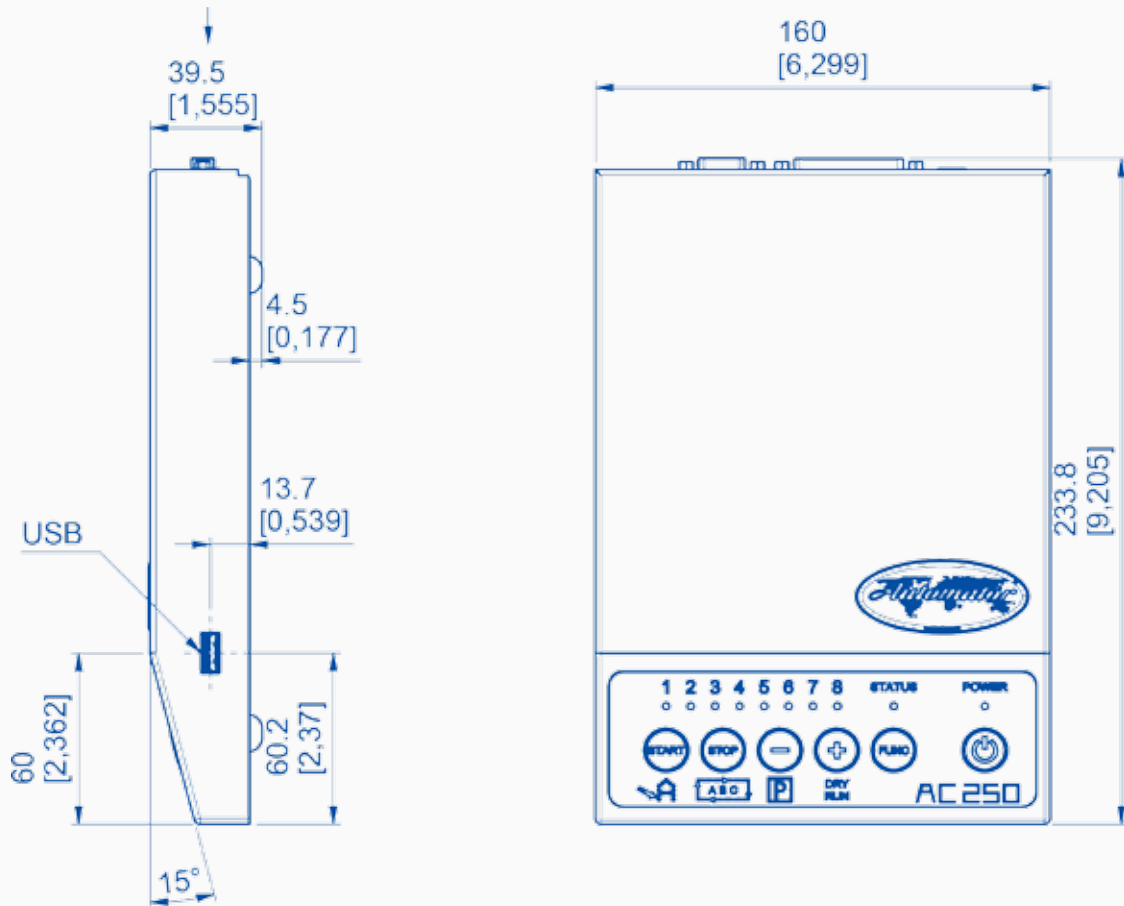

Standard Certifications for USA: (International Technology Equipment Safety part I: general requirements, 609501) and Canada (International Technology Equipment Safety part I: general requirements Amendment 1:2011, Amd. 2:2014, CSA C22.2#60950-1)



The AC250 controller can be used with a PC or alone with the special Automator MarkAlone™ Up to 8 programs management.

ADP2560

Marking area 1x2,3" - 25x60mm



PORTABLE

Dimensions: 4,5x13,7x8,5"
Weight: 7,3 lbs



INTEGRATION

Dimensions: 4,5x6,9x3,1"
Weight: 6,6 lbs



BENCHTOP

Use Automator dot peen marker easily
in both toolstand and portable mode
Dimensions: 16,1x24,3x12,4"



Marking area 1x4,7" - 25x120mm

ADP25120



PORTABLE

Dimensions: 4,5x12,7x8,5"
Weight: 9,3 lbs



INTEGRATION

Dimensions: 7,8x6,9x3,1"
Weight: 8,8 lbs



BENCHTOP

Use Automator dot peen marker easily
in both toolstand and portable mode
Dimensions: 16,1x24,3x12,4"

ADP5090

Marking area 1,9x3,5" - 50x90mm



PORTABLE

Dimensions: 14,4x10,7x4,7"
Weight: 11,8 lbs



INTEGRATION

Dimensions: 14,4x10,7x4,7"
Weight: 11 lbs



BENCHTOP

Dimensions: 16,1x24,3x12,4"



Marking area 4,7x6,3" - 120x160mm

ADP120160



PORTABLE

Dimensions: 17,2x10x7,9"
Weight: 19,6 lbs



INTEGRATION

Dimensions: 8,6x10,2x4,9"
Weight: 18,7 lbs



BENCHTOP

Dimensions: 16,1x24,3x12,4"

ADP120160 DEEP FOR DEEPER MARKINGS

Marking area 4,7x6,3" - 120x160mm



INTEGRATION

Dimensions: 8,6x10,2x6,7"
Weight: 21,8 lbs



Watch video now!

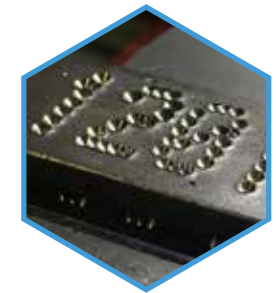

BENCHTOP

Dimensions: 16,1x24,3x12,4"



Marking area 11,8x15,7" - 300x400mm

ADP300400

FOR LARGEST
MARKING
AREAS



INTEGRATION

Dimensions: 20,2x16,7x5,8"
Weight: 46,3 lbs



BENCHTOP

Dimensions: 26,4x24,3x21,2"

ASM6090

SCRIBE MARKING

Marking area 2,3x3,5" - 60x90mm



INTEGRATION

Dimensions: 6,7x7,8x7,6"
Weight: 13,2 lbs

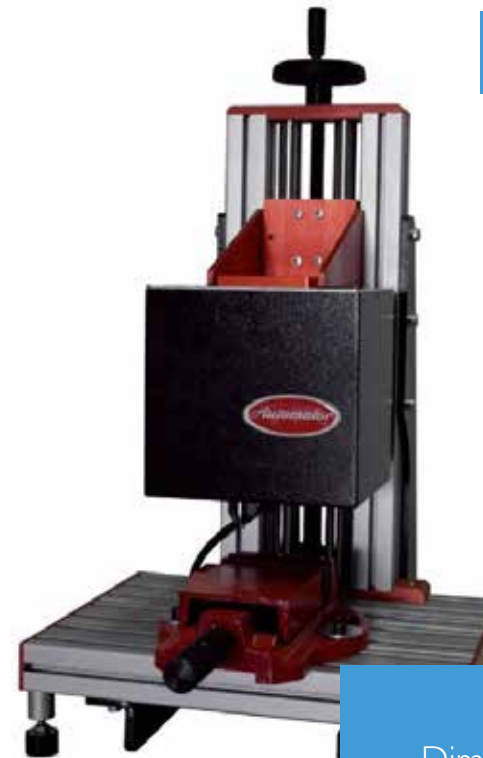

Watch video now!



BENCHTOP

Dimensions: 16,1x24,3x12,4"

Marking area 1,5x5,9" - 40x150mm

ASM40150

SCRIBE MARKING



INTEGRATION

Dimensions: 14,1x7,8x10,6"
Weight: 41,8 lbs



BENCHTOP

Dimensions: 30x24,3x16,5"

MARKING PINS

For all models

Pneumatic Controlled dot

Drive air
Return spring



3 - 6 mm dot



12 mm dot



18 mm dot



3 -6 mm XL dot

Pneumatic Vibrating dot

Drive air
Return spring



4 mm vibro



3 mm vibro

Electric

Solenoid
driven

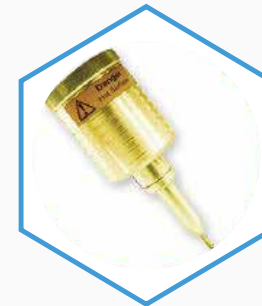

3 mm electric

Scribe pin

Contact marking
Silent marking



16 mm
for ASM40150



6 mm
for ASM6090

For all models

SOFTWARE

AC500

PC AC250

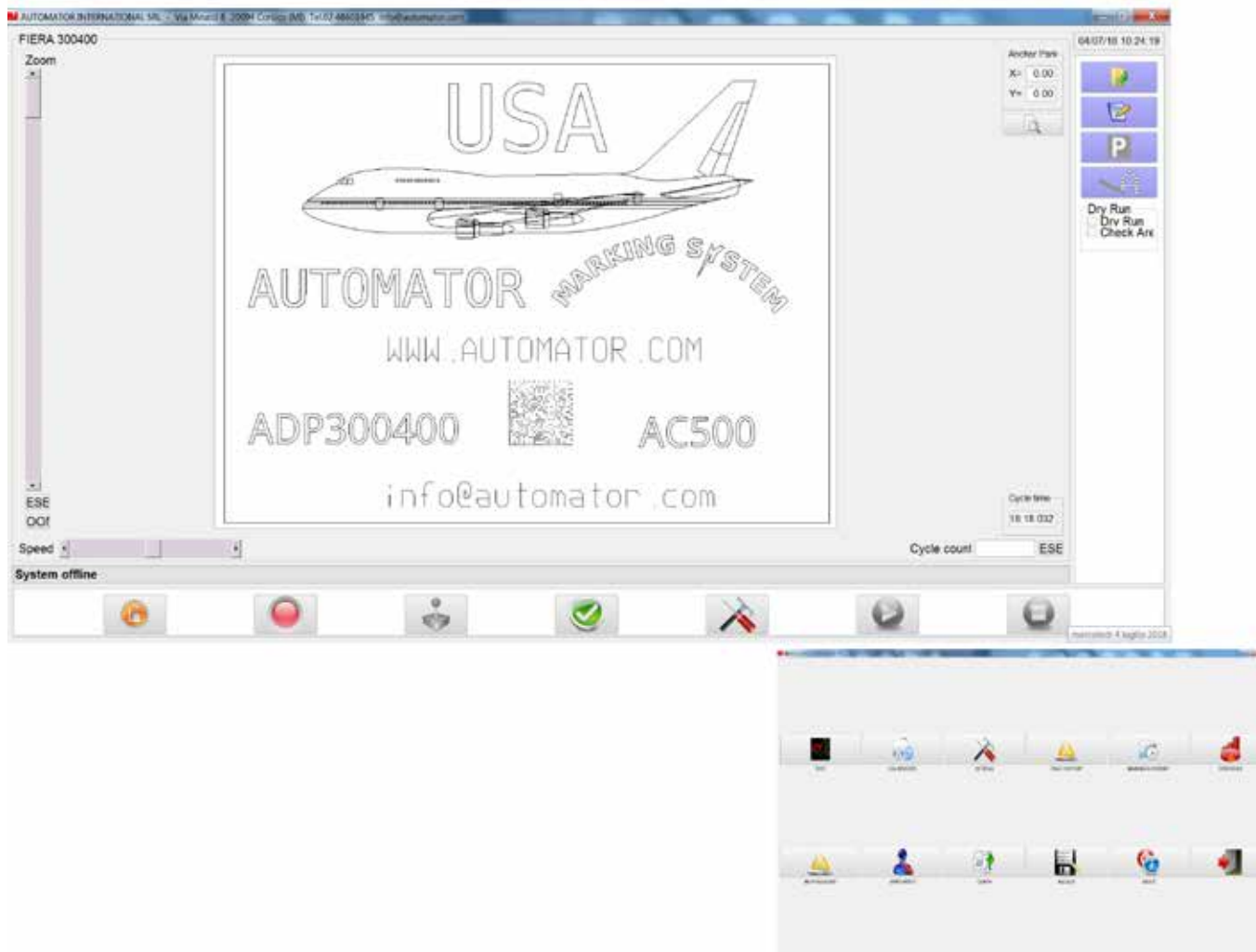

Software with intuitive and flexible interface, it allows a graphic freedom of absolute value.

Thanks to the touch screen graphic display, it is easy to navigate and to create messages to be marked and set its parameters, displaying also the time of the performance.

The preview allows to represent exactly what will be marked and any change in the message will be displayed instantly. The software provides for the creation of messages with the date in various formats, x or variable texts, codes, serial numbers, Data matrix and logos. Possible the creation of the programs on the PC, which can be easily transferred to the AC500 controller with USB stick or USB connection.

OPTIONS

For all models



X/Y axis
Stroke 11,8x11,8"
stepper motor, maximum
weight 88 lbs



Extension
For 1,5"
cartridge



Rubber protection for ADPs
To protect the marker from
dusts and infiltrations



Portable standoff
Handheld for ADP
markers



**Rotating axis to mark
on circumferences**
For diameters up to 3,7", stepper
motor, maximum weight 16,5 lbs



Command box
With start/stop buttons
and cable



Start marking pedal
With cable and adapter

For all models

OPTIONS



Plate holder

Plate fastening system with double spring anchoring for dot peen markers



Radial extension kit
3,3" and 5,2"



Portable kit

Two-handed handheld

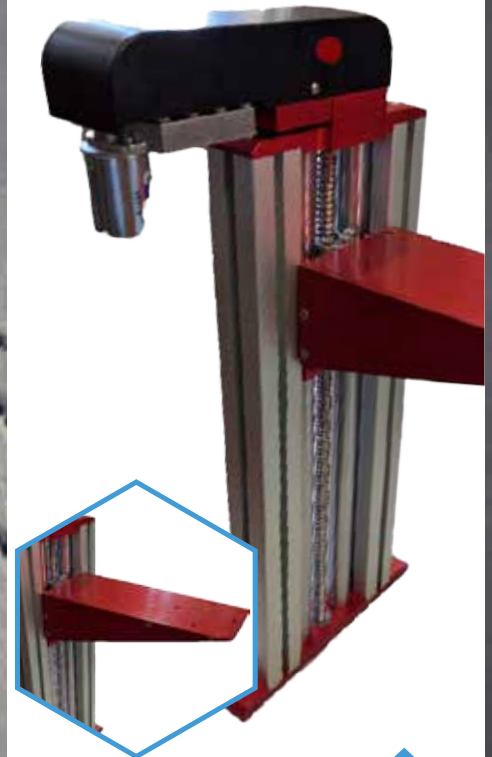

Manual or motorized Z axis

Available in height standard or up to 47"



Tag Feeder

Automatic dual guide tag feeder with electro-pneumatic pushing system that the registration of the height of the marking head.

Watch video now!

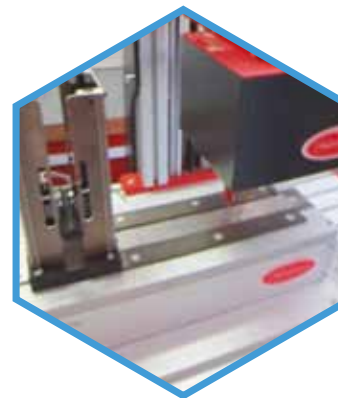

ADP5090

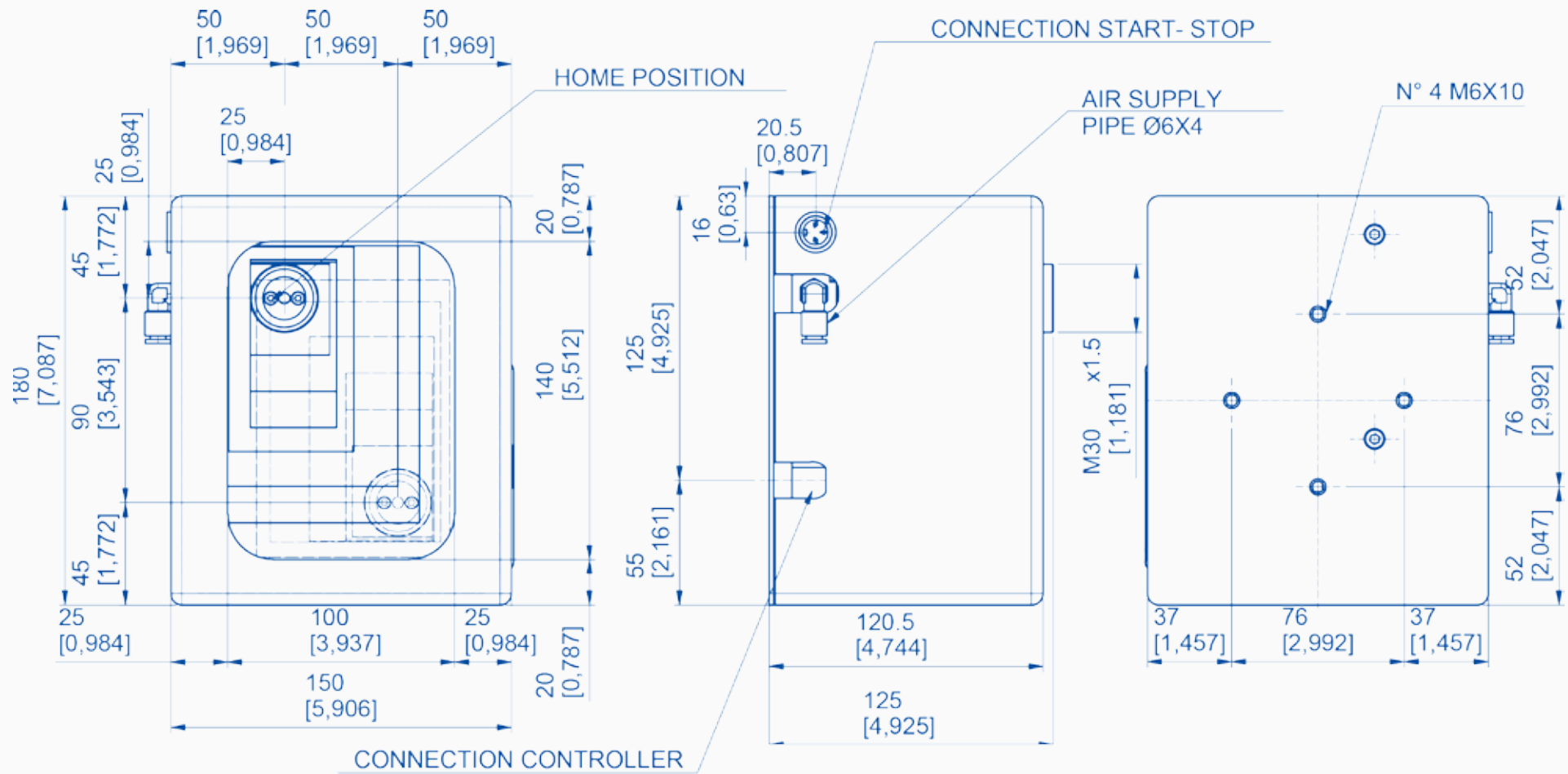

ADP120160

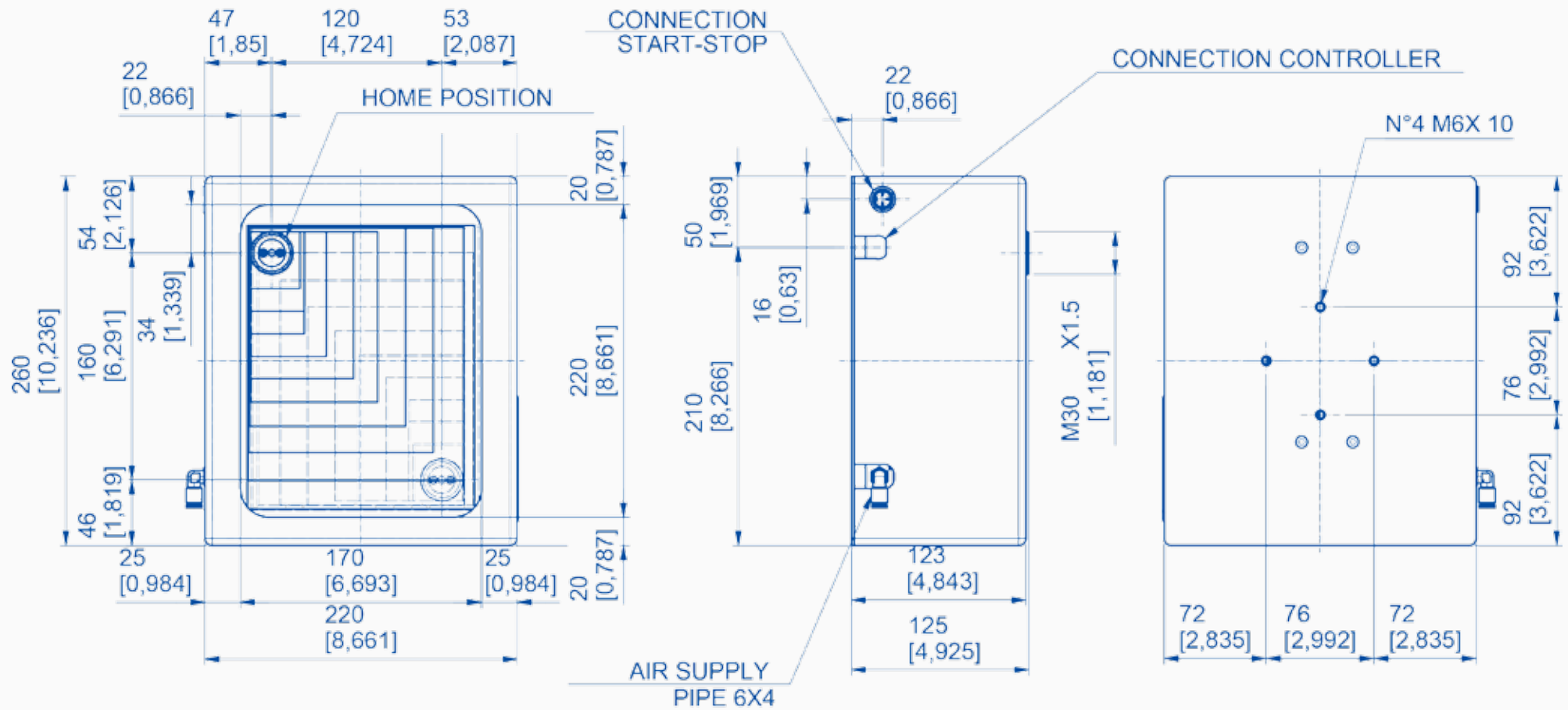

ADP120160 DEEP

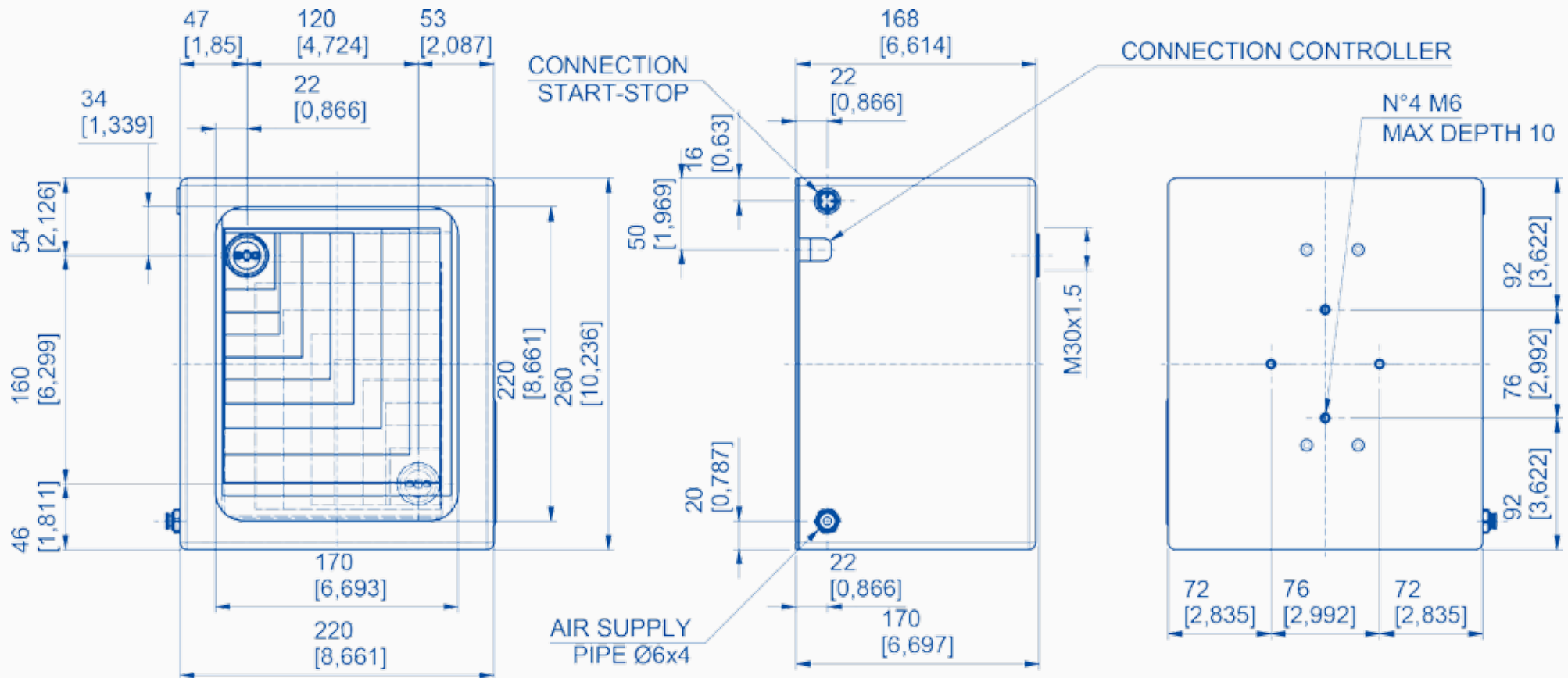

ADP300400

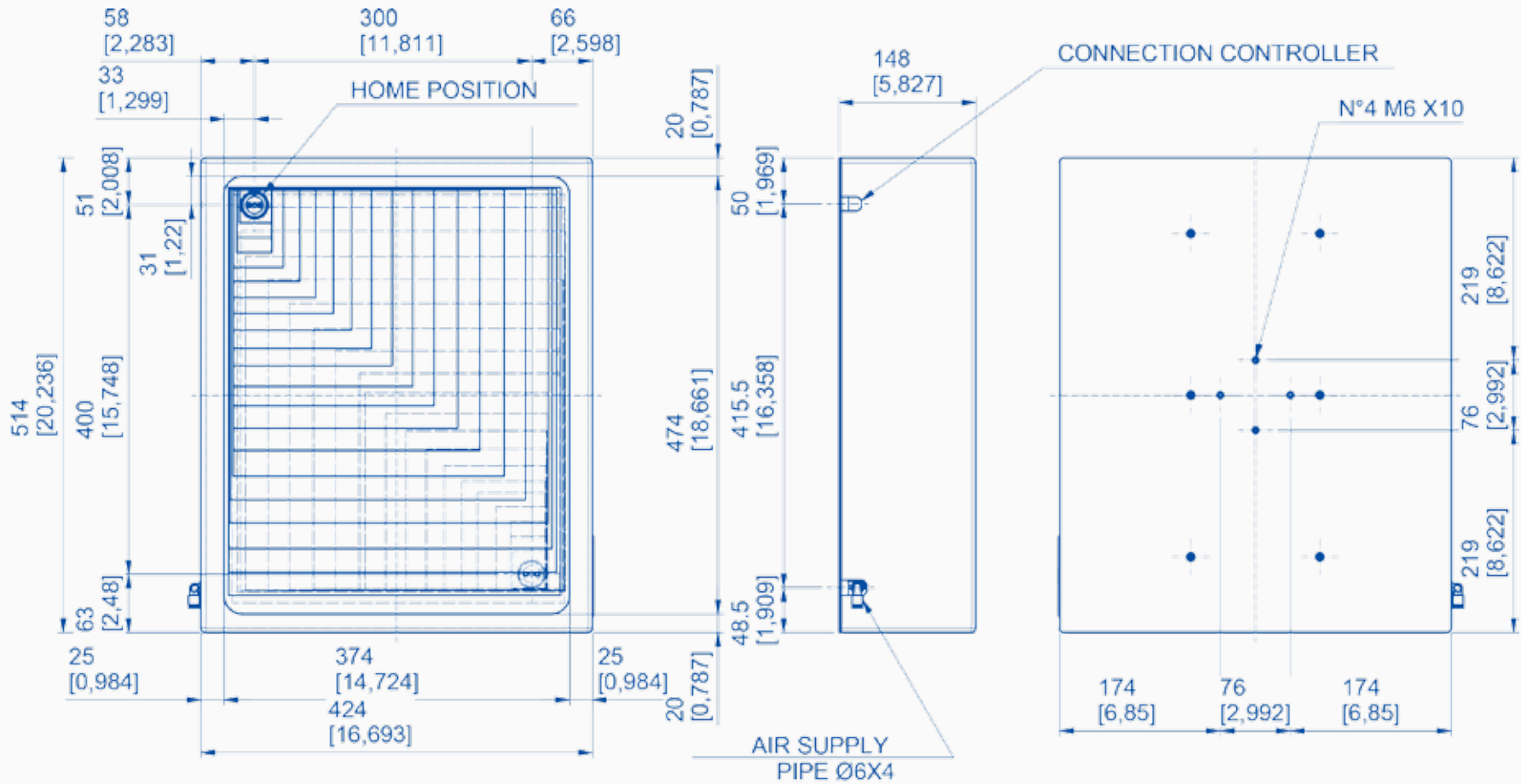

Drawings

ASM6090 SCRIBE MARKER

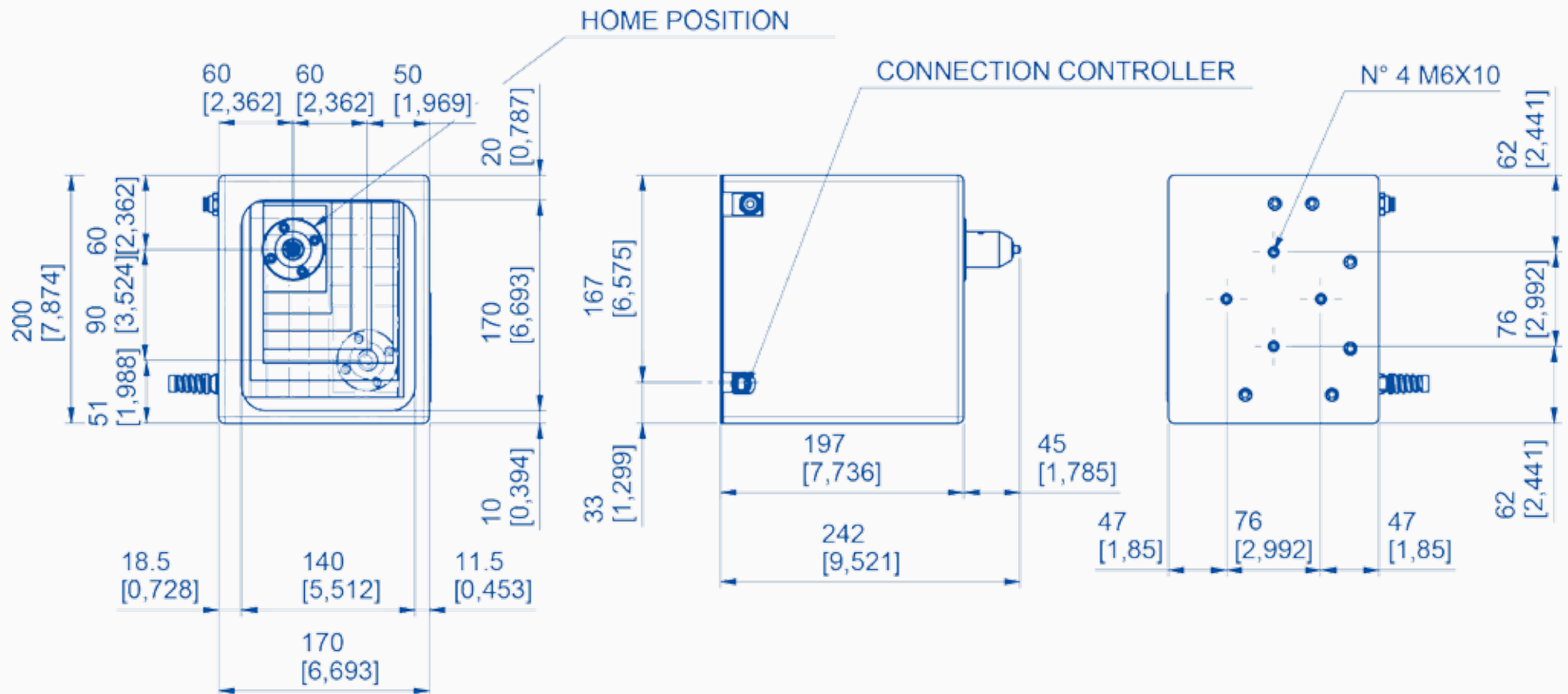

Drawings

ASM40150 SCRIBE MARKER

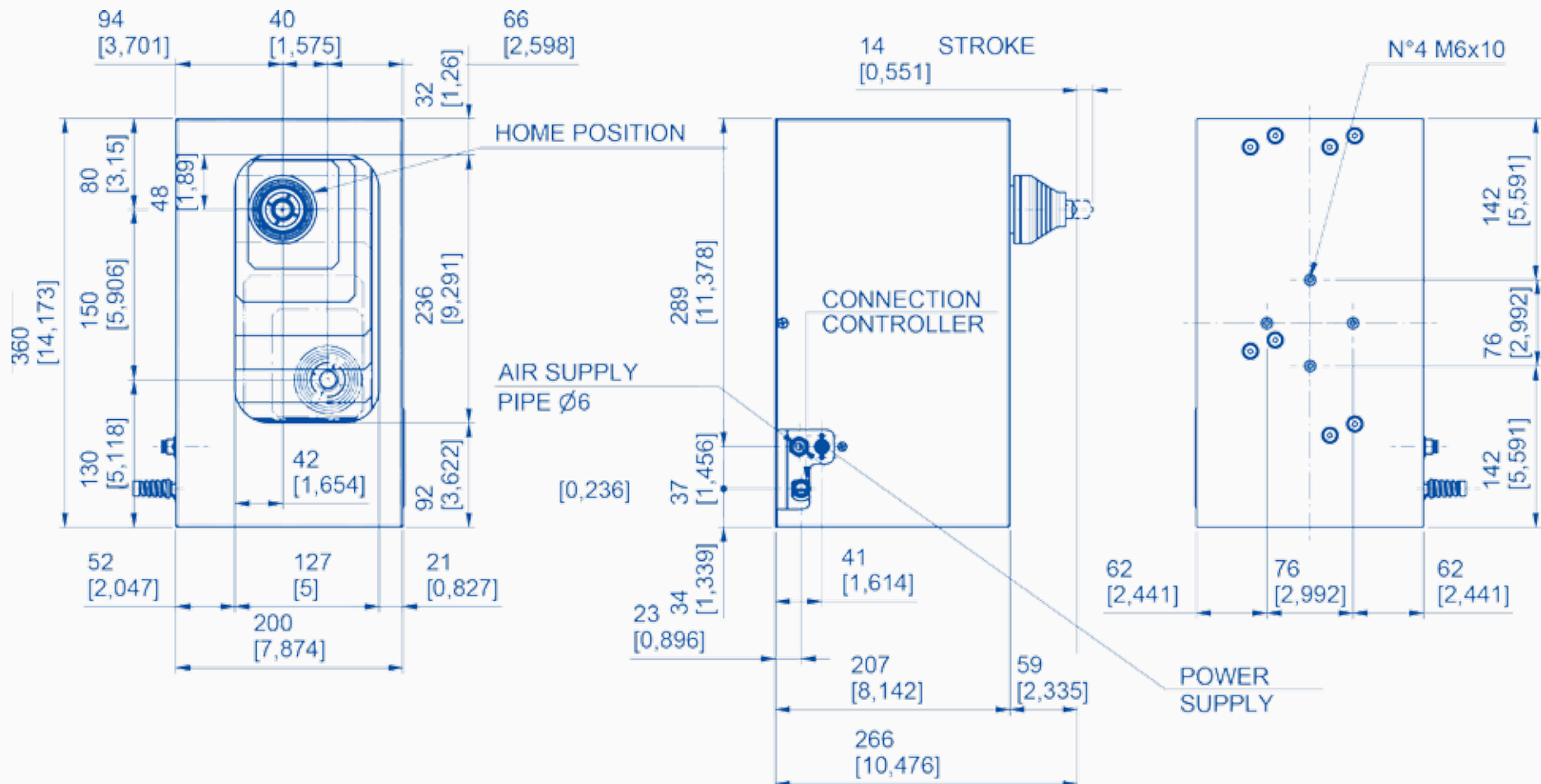

HANDHELDS

ADP2560

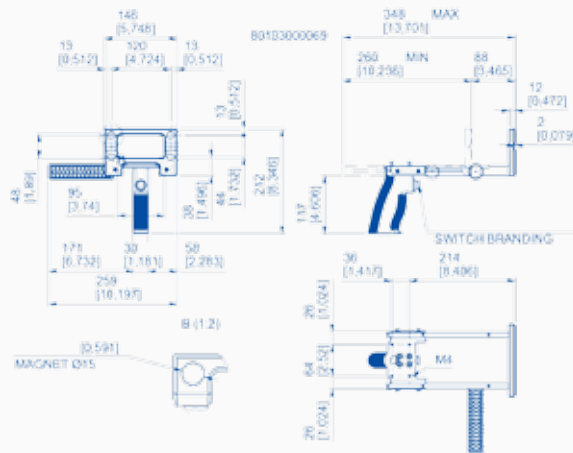

ADP25120

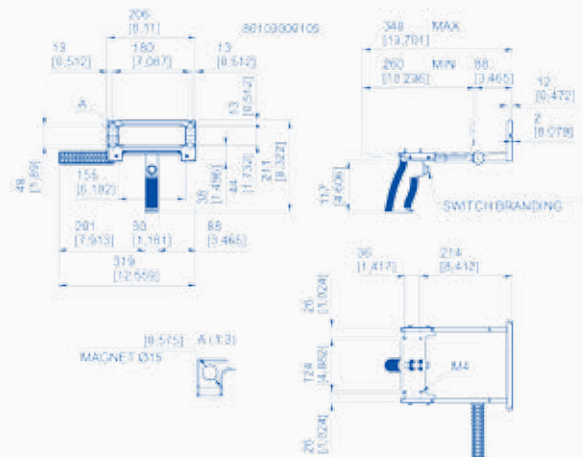

HANDHELDS

ADP2560

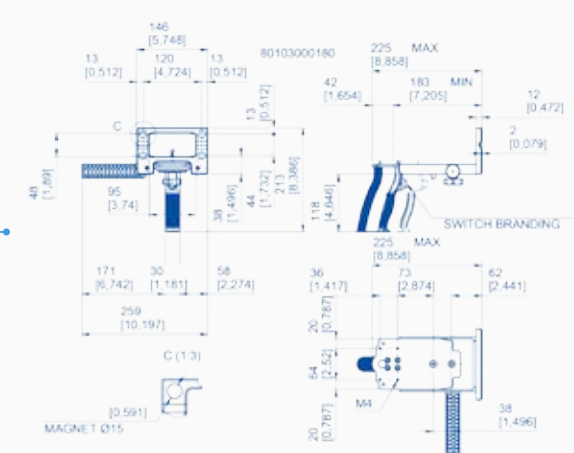

ADP25120

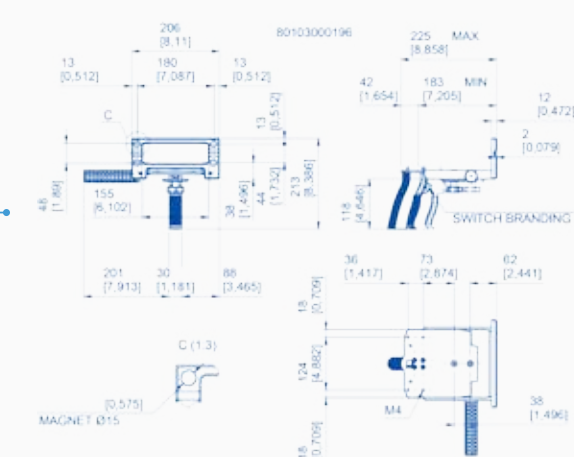

CONVERTIBLE KIT HANDHELD

TWO HANDS HANDHELDS

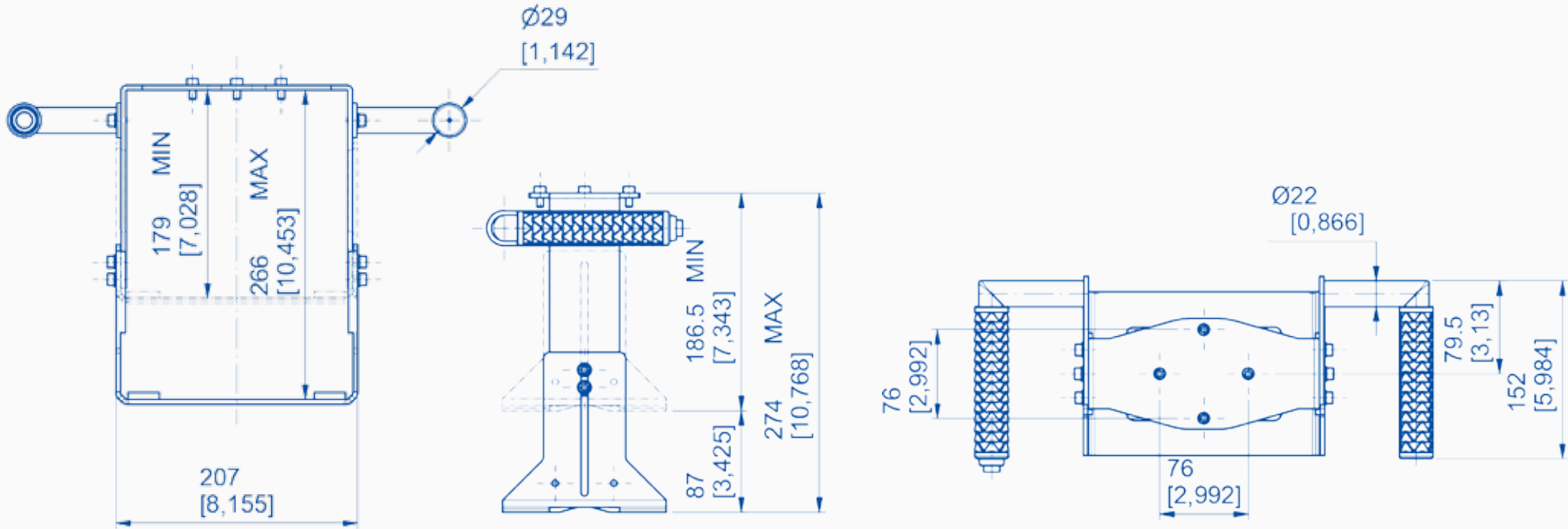

Drawings

STANDARD BENCHTOP
KIT - 31,5" AND 39,3" MM
OPTIONAL HEIGHTS
AVAILABLE

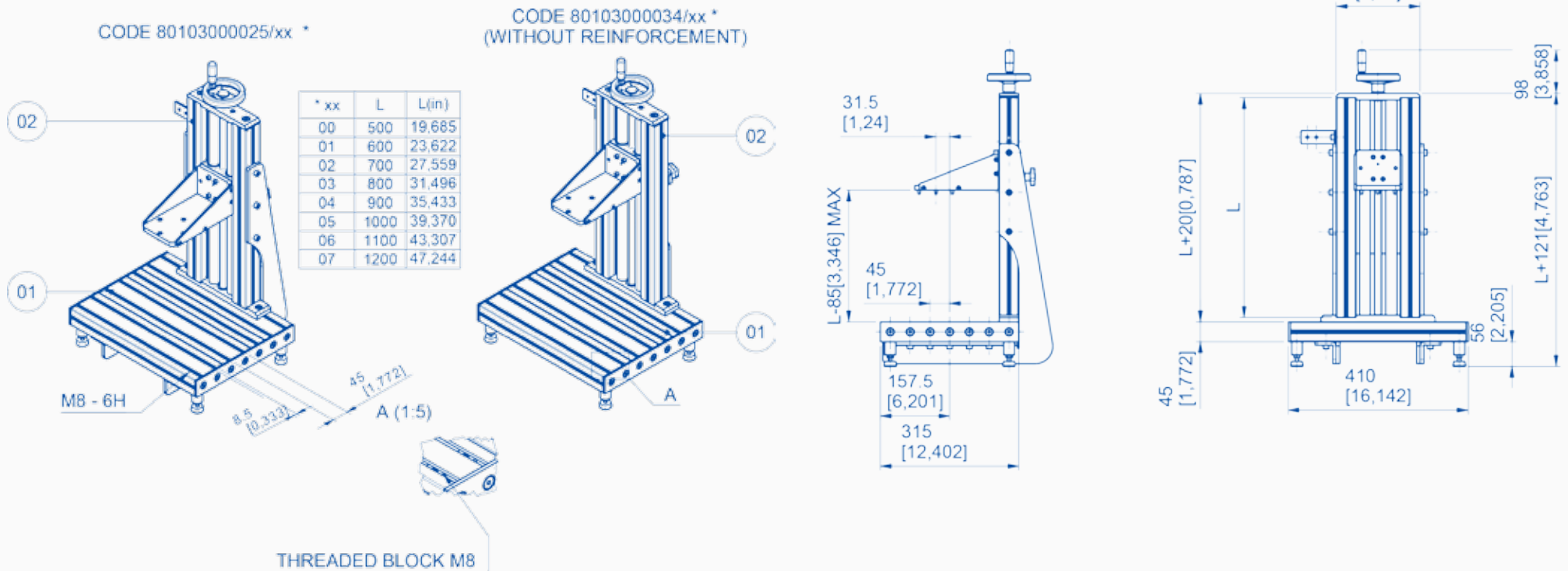

Drawings

ADP300400

STANDARD BENCHTOP
KIT - 31,5" AND 39,3" MM
OPTIONAL HEIGHTS
AVAILABLE

CODE 80103000028/xx *

CODE 80103000035/xx *
(WITHOUT REINFORCEMENT)

* xx	L	L(in)
00	500	19,685
01	600	23,622
02	700	27,559
03	800	31,496
04	900	35,433
05	1000	39,370
06	1100	43,307
07	1200	47,244

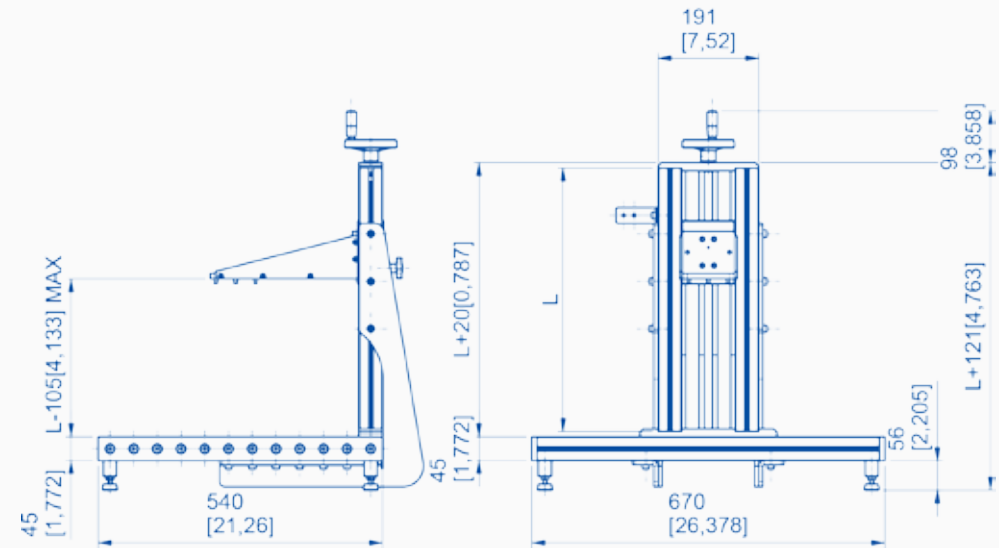
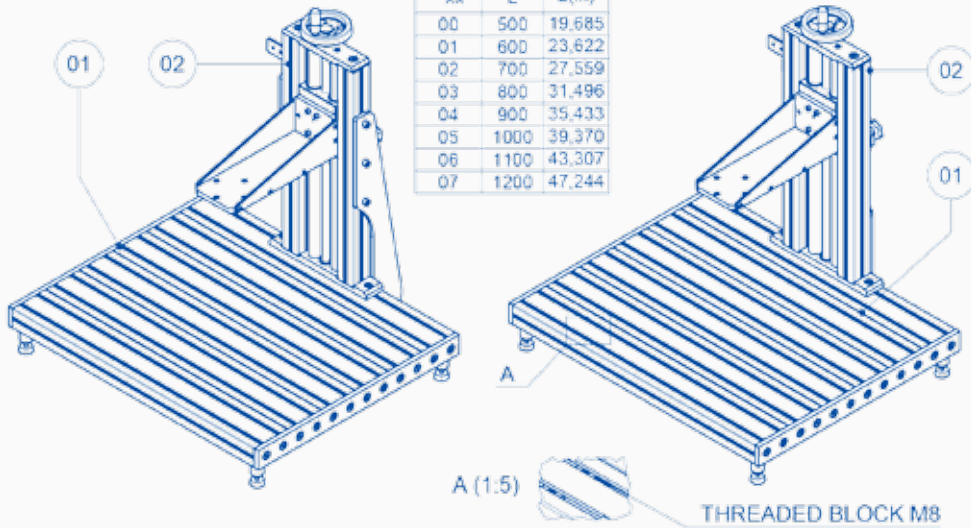

PINS

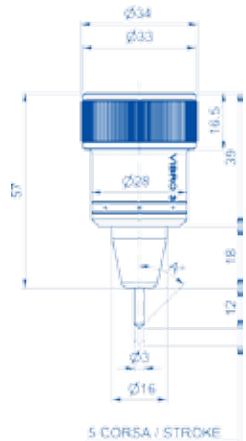

3 mm
vibro

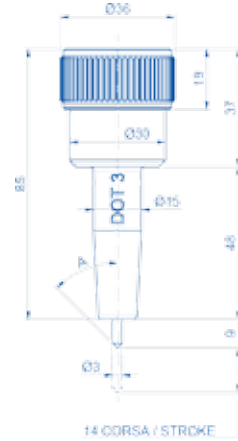

3 mm
dot

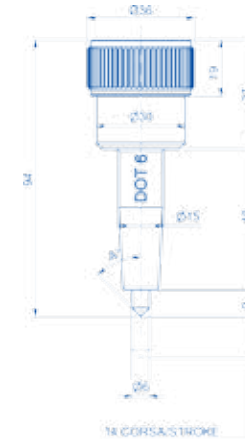

6 mm
dot

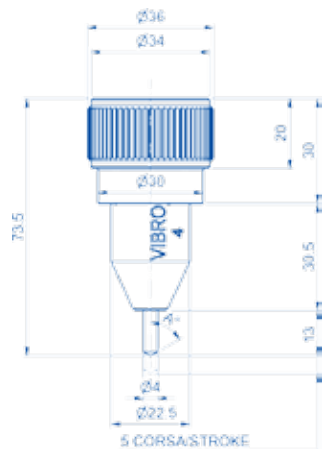

4 mm
vibro

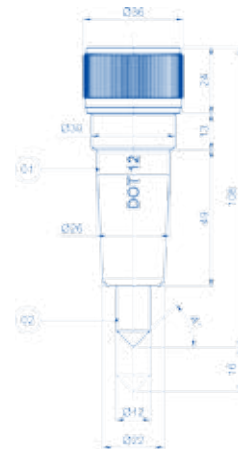

12 mm
dot



18 mm
dot

Drawings

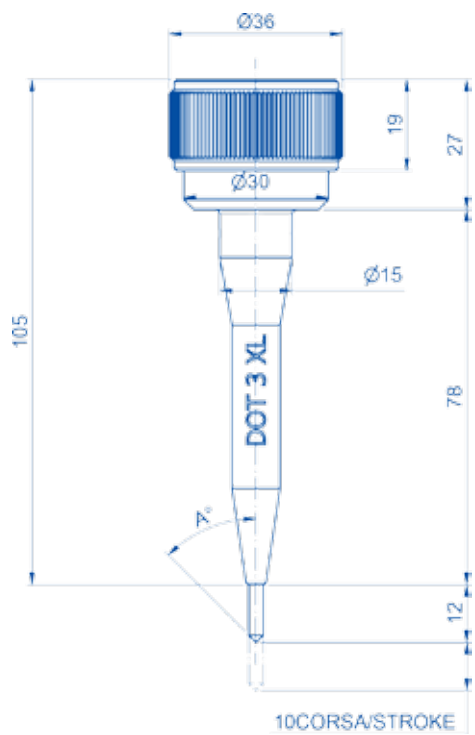

3 mm XL dot

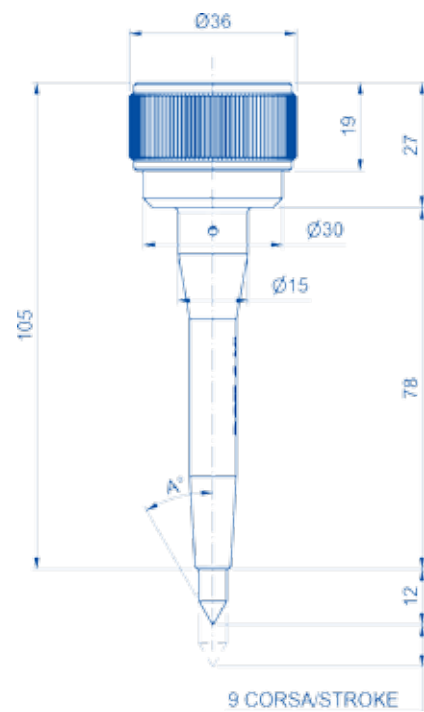

6 mm XL dot

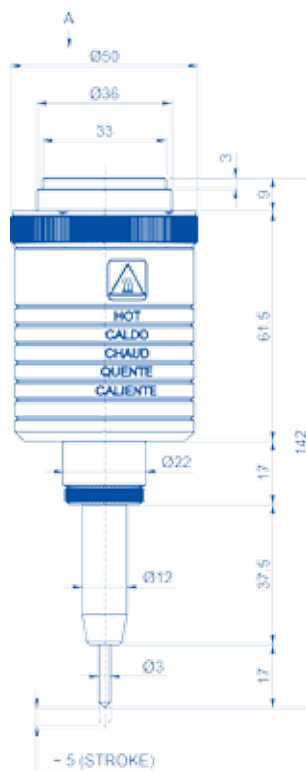

3 mm electro

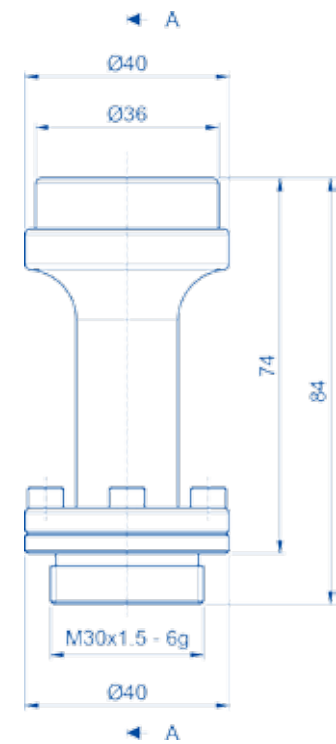

Vibro dot extension

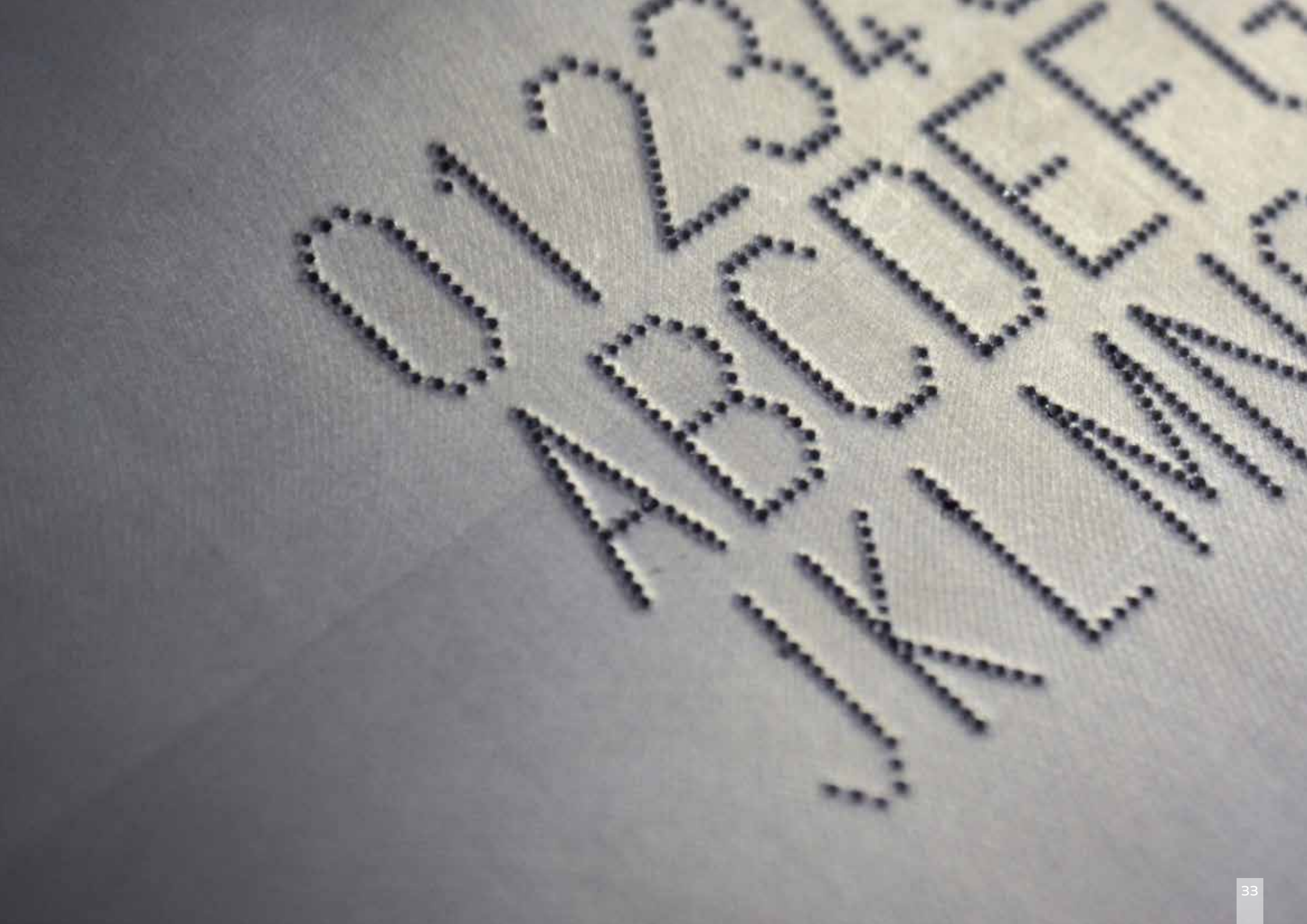

DOT PEEN MARKERS COMPARISON

FEATURES	ADP 2560	ADP25120	ADP5090	ADP120160	120160 DEEP	ADP300400	SCRIBE ASM6090	SCRIBE 40150
MARKING AREA	25x60 mm	25x120 mm	50x90 mm	120x160 mm	120x160 mm	300x400 mm	60x90 mm	40x150 mm
CONTROLLER	AC500 - AC250	AC500 - AC250	AC500 - AC250	AC500 - AC250	AC500 - AC250	AC500 - AC250	AC500	AC500
PORTABLE	Yes	Yes	Yes	Yes	Consult the company	No	Consult the company	Consult the company
BENCHTOP	Yes	Yes	Yes	Yes	Yes	Yes	Yes	Yes
INTEGRATION	Yes	Yes	Yes	Yes	Yes	Yes	Yes	Yes
DOT PIN								
3 mm	x	x	x	x		x		
3 XL mm	x	x	x	x		x		
6 mm	x	x	x	x		x		
6 XL mm	x	x	x	x		x		
12 mm	x	x	x	x	x	x		
18 mm	x	x	x	x	x	x		
VIBRO PIN								
3 mm	x	x	x	x		x		
4 mm	x	x	x	x		x		
ELECTRIC PIN								
3 mm	x	x	x	x		x		
SCRIBE PIN								
16 mm								x
4 mm							x	
NOISE	Moderate	Moderate	Moderate	Moderate	Moderate	Moderate	Very low	Very low
COMPUTER-HOST INTERFACE	Yes (RS232-ETH)	Yes (RS232-ETH)	Yes (RS232-ETH)	Yes (RS232-ETH)	Yes (RS232-ETH)	Yes (RS232-ETH)	Yes (RS232-ETH)	Yes (RS232-ETH)
COMPUTER REQUIRED	No	No	No	No	No	No	No	No
SPEED	Over 5 car/sec	Over 5 car/sec	Over 5 car/sec	Over 5 car/sec	Over 5 car/sec	Over 5 car/sec	Over 3 car/sec	Over 3 car/sec

DOT PEEN MARKERS COMPARISON

FEATURES	ADP 2560	ADP25120	ADP5090	ADP120160	120160 DEEP	ADP300400	SCRIBE ASM6090	SCRIBE 40150
TYPES MAXIMUM HEIGHT	25 mm	25 mm	50 mm	120 mm	120 mm	300 mm	60 mm	100 mm
SOFTWARED DRIVEN Z AXIS	Yes	Yes	Yes	Yes	Consult the company	Consult the company	No	No
NUMBER OF PINS	1	1	1	1	1	1	1	1
LINES	Yes	Yes	Yes	Yes	Yes	Yes	Yes	Yes
ARCS	Yes	Yes	Yes	Yes	Yes	Yes	Yes	Yes
TYPES IN CONTINUOUS	Yes	Yes	Yes	Yes	Yes	Yes	Yes	Yes
LOGOS	Yes	Yes	Yes	Yes	Yes	Yes	Yes	Yes
QR CODES, BAR CODES AND DATAMATRIX	Yes	Yes	Yes	Yes	Yes	Yes	Yes	Yes
SERIES	Yes	Yes	Yes	Yes	Yes	Yes	Yes	Yes
DATE CODES	Yes	Yes	Yes	Yes	Yes	Yes	Yes	Yes
IRREGULAR SURFACES	Over 10 mm	Over 10 mm	Over 10 mm	Over 10 mm	Over 7 mm	Over 10 mm	Over 7 mm	Over 7 mm
CIRCUMFERENCES	Consult the company	Consult the company	Yes	Yes	Yes	Yes	No	No
N° OF FONTS	3	3	3	3	3	3	3	3
FONT FROM THE CUSTOMER	Yes	Yes	Yes	Yes	Yes	Yes	Yes	Yes
RESOLUTION	Over 700 px/cm	Over 700 px/cm	Over 700 px/cm	Over 700 px/cm	Over 700 px/cm	Over 700 px/cm	in continuous	in continuous
POWER	100-240 Vac 50-60 Hz	100-240 Vac 50-60 Hz	100-240 Vac 50-60 Hz	100-240 Vac 50-60 Hz	100-240 Vac 50-60 Hz	100-240 Vac 50-60 Hz	100-240 Vac 50-60 Hz	100-240 Vac 50-60 Hz
AIR SUPPLY	1-7 Bars	1-7 Bars	1-7 Bars	1-7 Bars	1-10 Bars	1-7 Bars	1-7 Bars	1-7 Bars

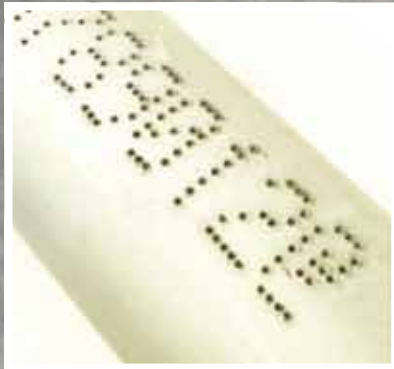
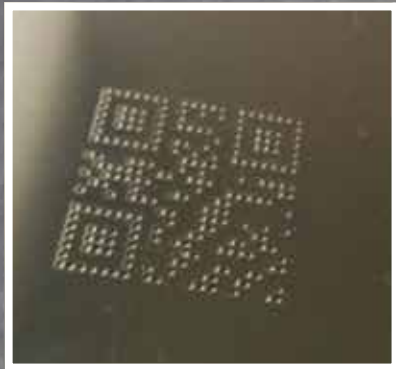



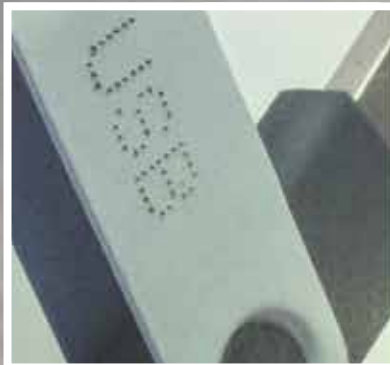
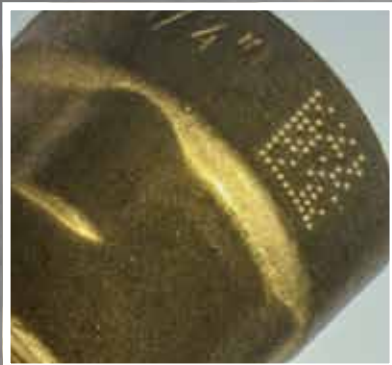

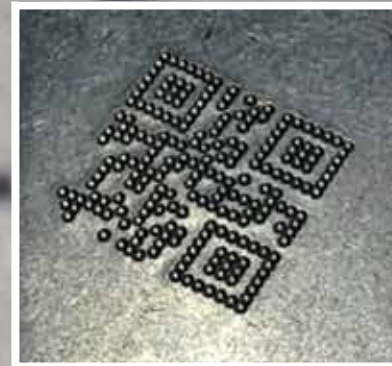
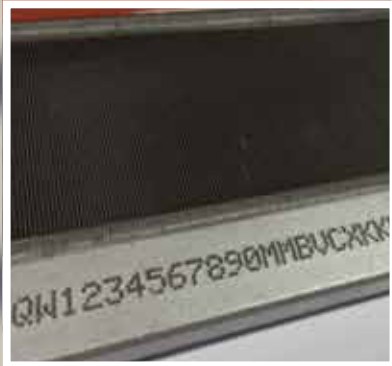

THE BIGGEST MARKING **FAMILY** IN THE WORLD.



AUTOMATOR INTERNATIONAL SRL: via Meucci 8, 20094 Corsico (MI) Italy Tel: + 39 02.48601445 – info@automator.com

www.automator.com

